

HENRY PARK PRIMARY SCHOOL

MATHEMATICS
PRIMARY 4

Name: _____ ()

Parent's Signature

Class: Primary 4 _____

Duration of Paper: 1 h 45 min

Marks:

Section A (MCQ)	20
Section B (Open-Ended)	50
Section C (Problem Sums)	30
Total	100

Section A: Multiple Choice Questions (10 x 2 marks = 20 marks)

Read each question carefully. For each question, 4 options are given. One of them is the correct answer. Make your choice (1, 2, 3 or 4). Shade the correct ovals on the Optical Answer Sheet.

1. In which of the following numbers does the digit 8 stand for 800?

(1) 5708

(2) 5870

(3) 7085

(4) 8570

()

2. In which of the following are the numbers arranged from the smallest to the greatest?

(1) 1523, 1532, 1352

(2) 1352, 1523, 1532

(3) 1352, 1532, 1523

(4) 1532, 1523, 1352

()

3. Which of the following fractions is in its simplest form?

(1) $\frac{4}{7}$

(2) $\frac{2}{6}$

(3) $\frac{3}{9}$

(4) $\frac{4}{10}$

()

4. Which of the following decimals is the smallest?

(1) 3.06

(2) 3.14

(3) 3.027

(4) 3.203

()

5. $10.56 \times 9 =$ _____

(1) 19.56

(2) 90.04

(3) 90.56

(4) 95.04

()

6. In the figure, which angle is greater than a right angle?

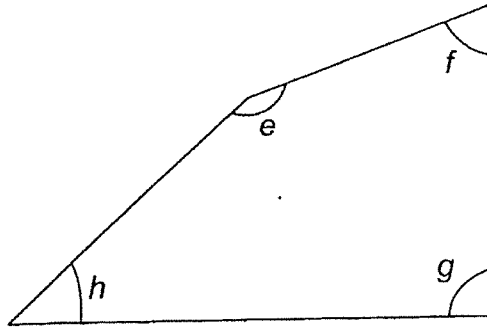

- (1) $\angle e$
- (2) $\angle f$
- (3) $\angle g$
- (4) $\angle h$

()

7. The figure below is made up of rectangle P and square Q. Find the area of square Q.

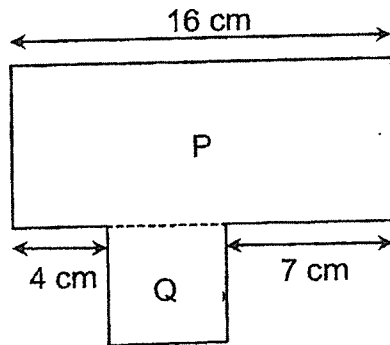

- (1) 16 cm^2
- (2) 20 cm^2
- (3) 25 cm^2
- (4) 27 cm^2

()

8. The table below shows the number of children in each family in a neighbourhood.

Number of children in each family	0	1	2	3	4	5
Number of families	9	16	20	25	8	3

How many families have more than 3 children?

- (1) 11
- (2) 25
- (3) 36
- (4) 45

()

9. There are 35 children on a bus. $\frac{3}{5}$ of the children are boys.

How many girls are there on the bus?

- (1) 7
- (2) 14
- (3) 21
- (4) 32

()

10. James drew three straight lines such that there are both parallel and perpendicular lines in a square grid. Which of the following are the lines that he drew?

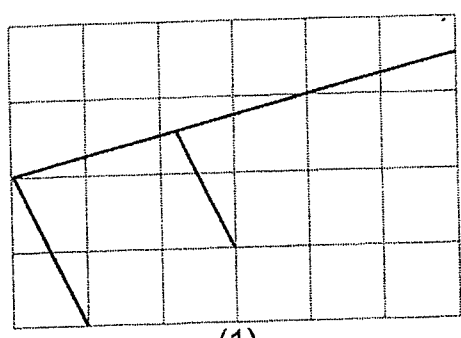

(1)

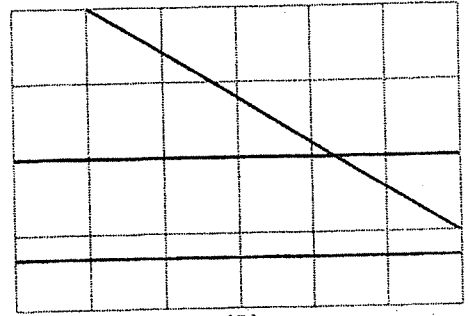

(2)

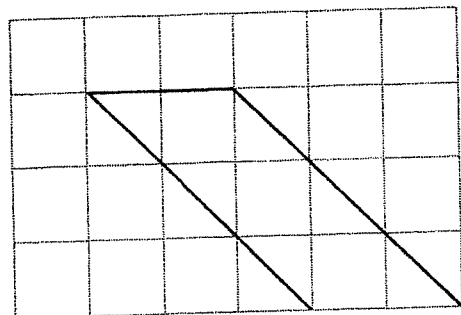

(3)

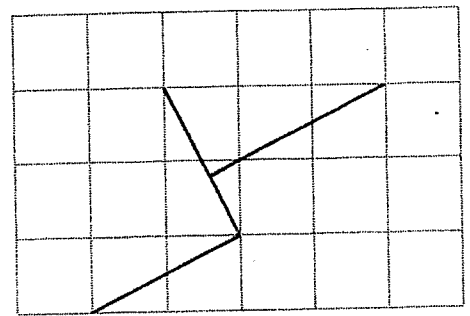

(4)

()

(Go on to Section B)

NAME: _____

CLASS: Primary 4 _____

Section B: Open-Ended Questions (25 × 2 marks = 50 marks)

Read the questions carefully and write the correct answer in the blanks provided.
Show all workings clearly.

11. Write sixty-seven thousand, eight hundred and ninety-five in figures.

Ans: _____

12. Some factors of 20 are 1, 2, 4 and 20. What are the other two factors of 20?

Ans: _____ and _____

13. $4488 + 6 =$ _____

Ans: _____

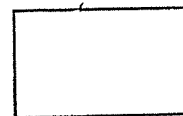

14. What is the value of $\frac{9}{10} + \frac{4}{5}$?

Express your answer as a mixed number.

Ans: _____

15. Arrange the following fractions from the greatest to the smallest.

$$\frac{2}{3}, \quad \frac{3}{4}, \quad \frac{5}{12}$$

Ans: _____, _____, _____
(greatest) (smallest)

16. What fraction of the stars shown are shaded grey?

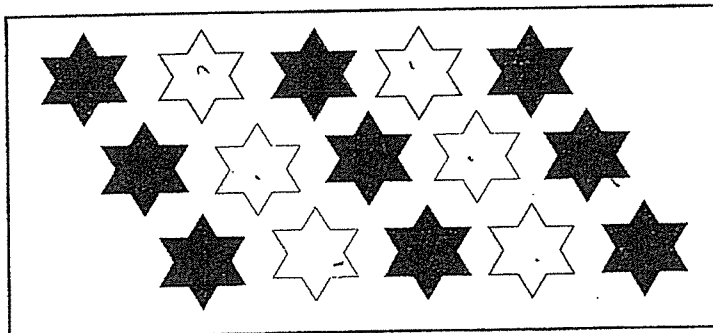

Ans: _____

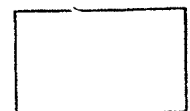

17. Write the decimal represented by A.

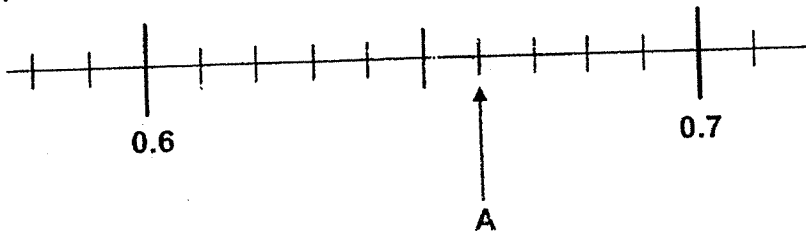

Ans: _____

18. Round 27.65 to the nearest whole number..

Ans: _____

19. In the figure below, name the smallest angle.

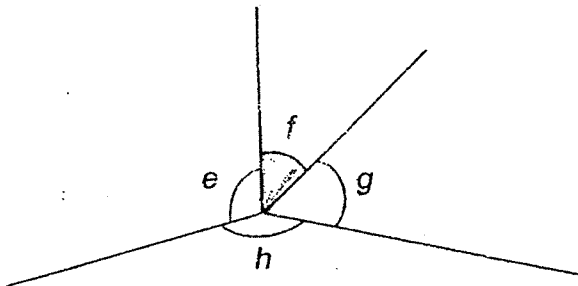

Ans: \angle _____

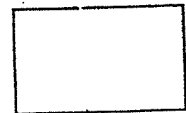

20. The side of a square measures 7 cm. What is the perimeter of the square?

Ans: _____ cm



21. The graph below shows Jimmy's height when he was 8 to 13 years old.

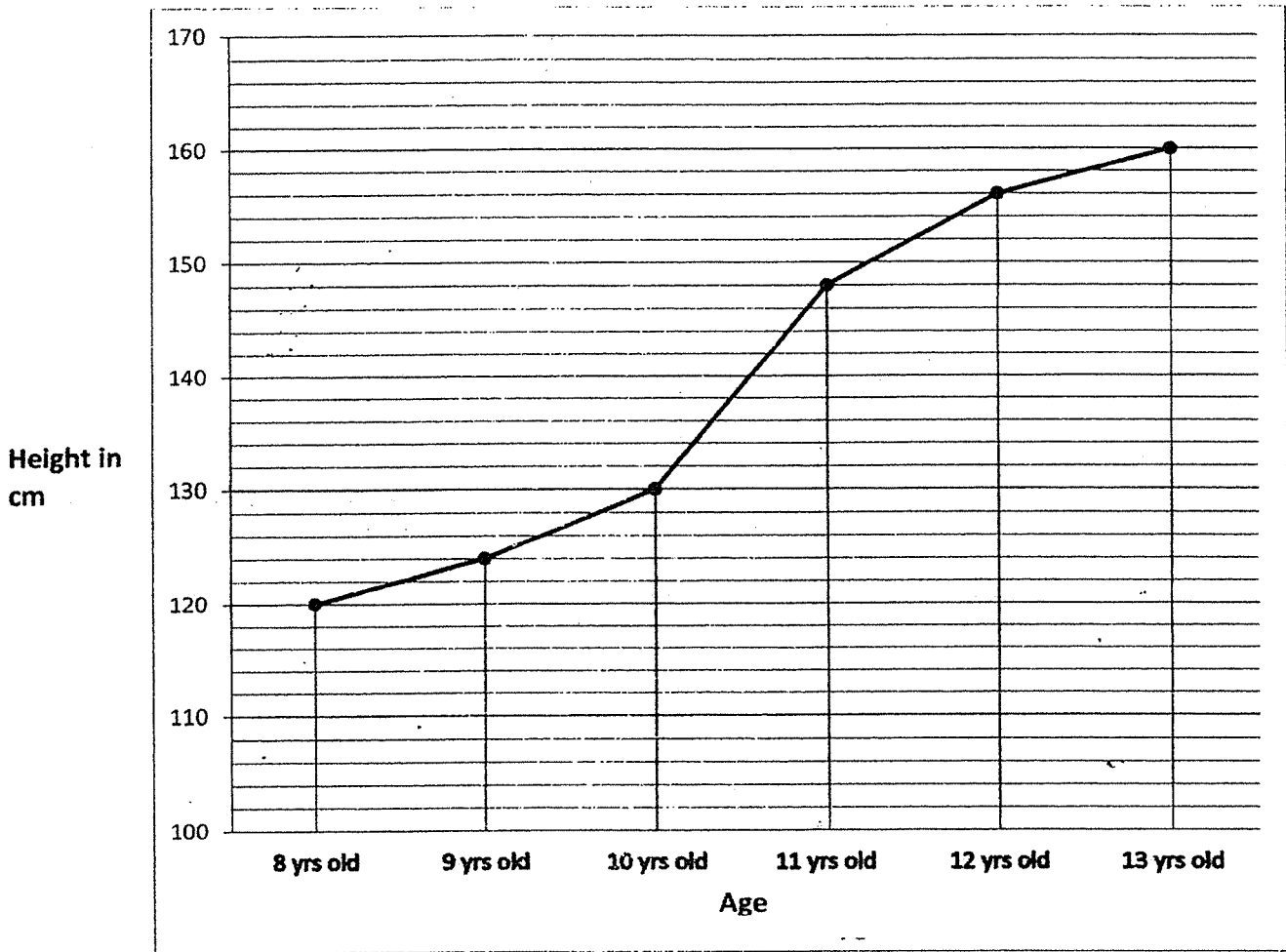

What was the increase in his height between 10 to 11 years old?

Ans: _____ cm



22. The table below shows the prices of movie tickets in a cinema.

	Types of movie	Ticket Prices	
		Adult	Children
Monday to Thursday	2D	\$6.50	\$4
	3D		
Friday to Sunday	2D	\$9.00	\$4
	3D	\$12.50	\$4

Mr and Mrs Selva and their 2 children wanted to watch a 3D movie.
How much more would the movie tickets cost in total if they watched the 3D movie on a Saturday than on a Monday?

Ans: \$ _____

23. A wooden box with 5 identical books has a mass of 3.55 kg. The mass of the wooden box is 1.25 kg when empty. What is the mass of each book?

Ans: _____ kg

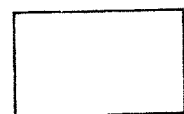

24. Kathy mixed 1.2 l of orange juice with 0.95 l of apple juice to make a bottle of fruit punch. How many litres of fruit punch were there in three such bottles?

Ans: _____ l

25. Measure and write down the size of $\angle ABC$.

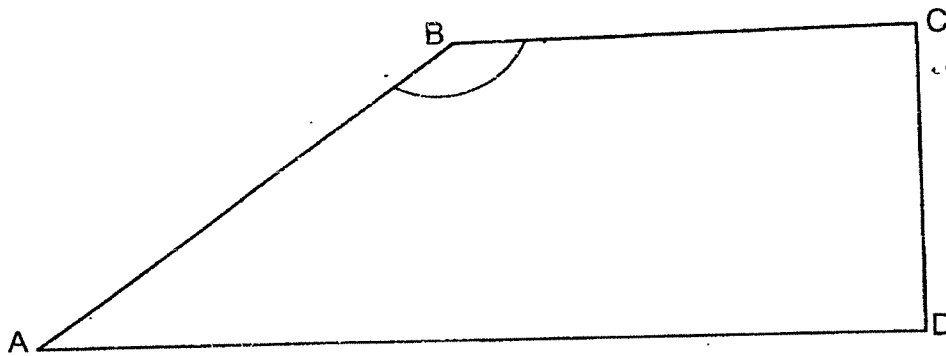

Ans: _____ °



26. In the figure, PQRS is a square. SRY is a straight line. $\angle PRX = 25^\circ$

Find $\angle XRY$.

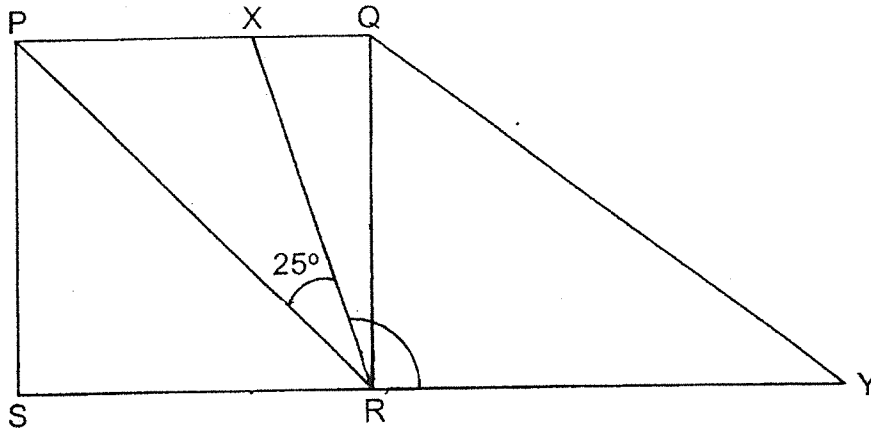

Ans: _____ °

27. The figure below is made up of 2 squares and 2 rectangles. Find the perimeter of the figure.

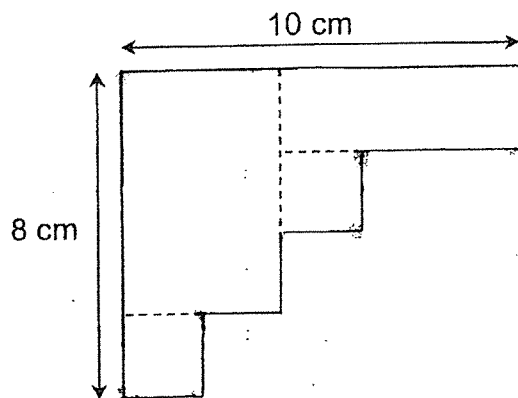

Ans: _____ cm

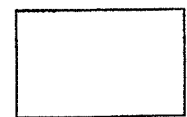

28. Mrs Tan took 1 h 45 min to cook dinner. She finished cooking dinner at 6 p.m. What time did she start cooking dinner? Give your answer in the 24-hour clock.

Ans: _____

29. The table below shows the number of hamburgers sold in a canteen in a week. Each hamburger was sold at \$2.

Day	Monday	Tuesday	Wednesday	Thursday	Friday
Number of hamburgers sold	13	20	27	32	18

Find the total amount of money collected from the sale of hamburgers from Wednesday to Friday.

Ans: \$ _____

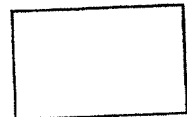

30. The graph below shows the amount of money Siti saved from June to September. She saved a total of \$700 in the four months. In the graph below, draw the bar to show the amount of money Siti saved in September.

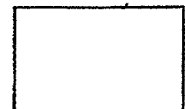
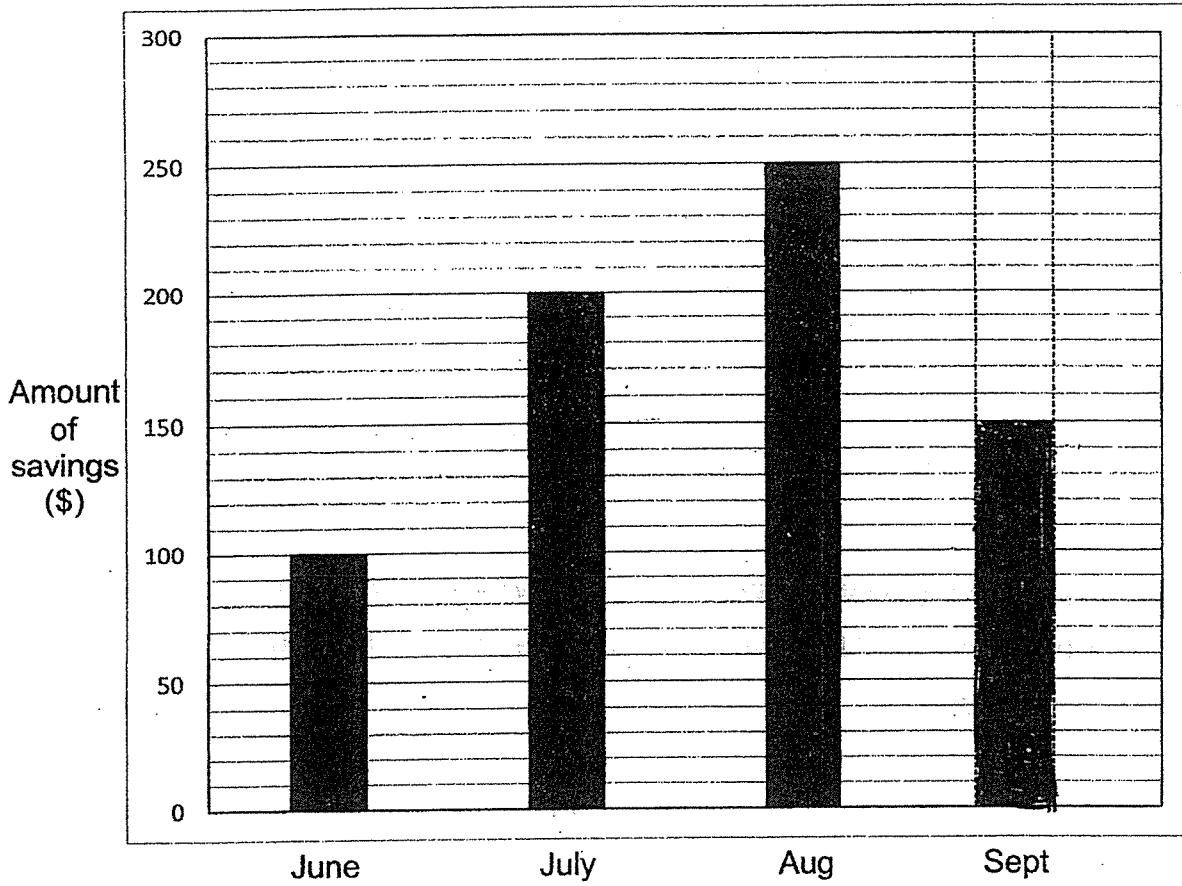

31. 10 identical ties and 6 identical shirts cost \$60.
5 such ties cost as much as 3 such shirts. What is the cost of one such shirt?

Ans: \$ _____

32. David and Alice have a total of \$240. Alice has twice as much money as David.
How much money must Alice give to David so that they will have the same amount of money?

Ans: \$ _____

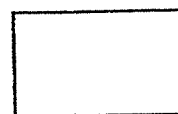

33. John bought 8 identical markers. He gave the cashier \$20 and received a change of \$7.60. What is the cost of one marker?

Ans: \$ _____

34. Mr Chen weighed himself on a weighing scale as shown below. When he rounded his mass to 1 decimal place, his mass was 59.8 kg. What is the greatest possible mass shown on the weighing scale?

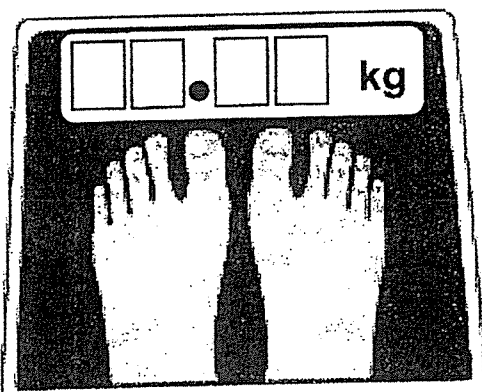

Ans: _____ kg

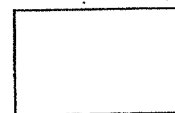

35. In the figure, AB is a line of symmetry. Shade 2 unit squares in the square grid to form a symmetrical figure.

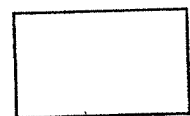
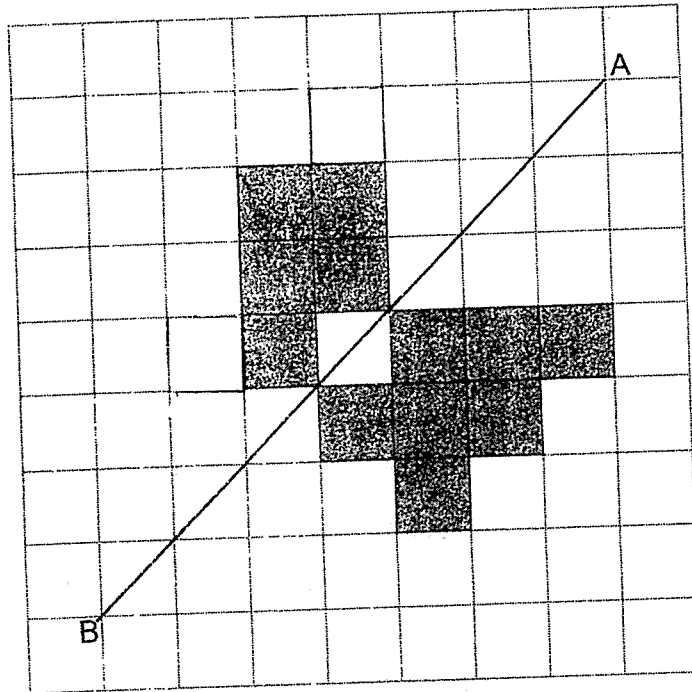

NAME: _____

CLASS: Primary 4: _____

Section C: Problem Sums (30 marks)

Read the following problem sums carefully. You may draw models to help you. Show all workings clearly and write your answers in the spaces provided. The number of marks allocated is shown in brackets [] at the end of each question.

36. Sarah bought some pears and packed them into boxes of 15. After packing the pears into 125 such boxes, she had 7 pears left.
- (a) How many pears did Sarah buy?
 - (b) How many more pears must Sarah buy so that she can have 180 such boxes of pears?

Ans: (a) _____ [2]

(b) _____ [2]



37. At a supermarket, packets of coffee beans are sold only in boxes of 3 as shown below. The cost of each box is \$12.50. The mass of each packet of coffee beans is 0.8 kg.

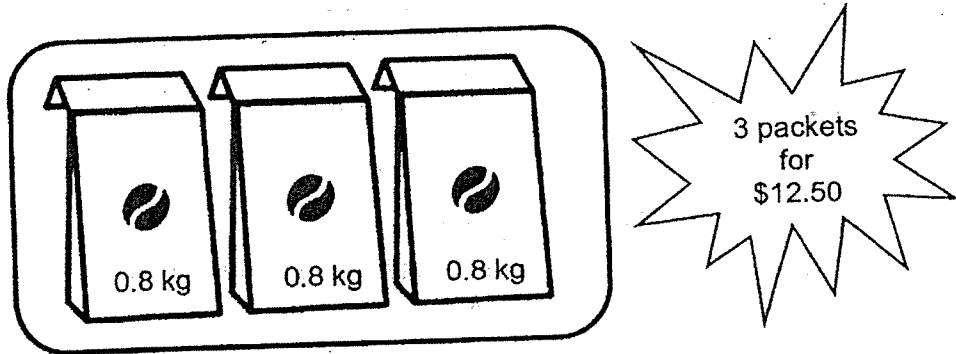

- (a) What is the total mass of 9 such packets of coffee beans?
(b) How much would 12 such packets of coffee beans cost?

Ans: (a) _____ [2]

(b) _____ [2]

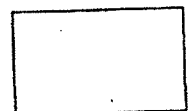

38. On a weekend, Ben spent a total of 3 h 10 min revising for his English, Science and Mathematics tests. He took 50 min to revise for his English test and 1 h 25 min to revise for his Science test.

(a) How long did Ben take to revise for his Mathematics test?
Express your answer in minutes.

(b) Ben began revising for his Science test in the evening at the time shown on the clock below. What time did he finish revising for his Science test? Express your answer in the 24-hour clock.

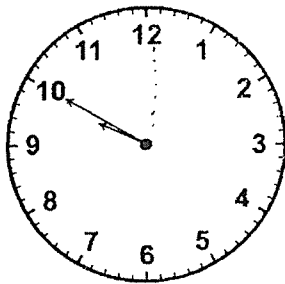

Ans: (a) _____ [2]

(b) _____ [2]

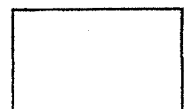

39. John collected 300 bookmarks. He gave $\frac{7}{10}$ of them to Bill, $\frac{1}{5}$ of them to Alice and kept the rest for himself.

- (a) What fraction of the bookmarks did John keep for himself?
(b) How many more bookmarks did John give to Bill than Alice?

Ans: (a) _____ [1]

(b) _____ [2]

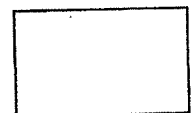

40. The diagrams below show a rectangular cardboard X and a square Y.

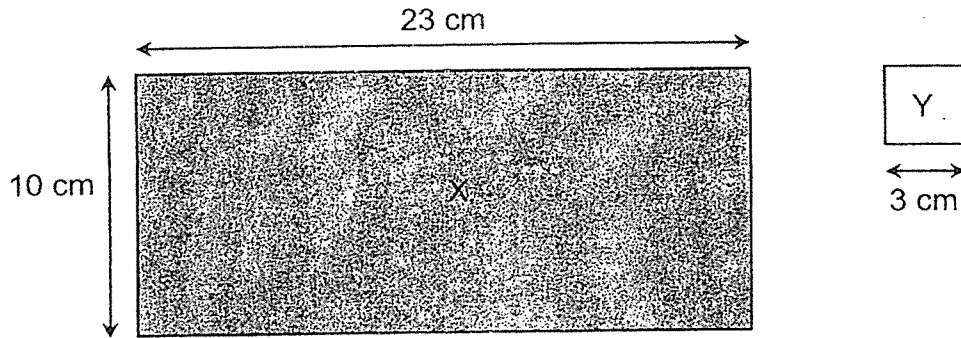

Ali cut as many square Y as he could from rectangular cardboard X. The remaining part of rectangular cardboard X is shown in Figure 1 below.

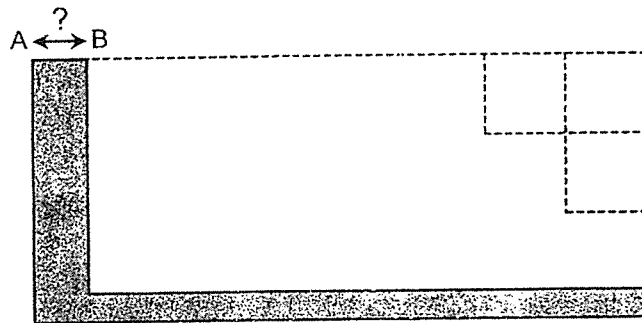
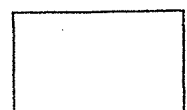

Figure 1

- What is the length of AB as shown in Figure 1?
- What is the greatest number of square Y that Ali could cut from rectangular cardboard X?

Ans: (a) _____ [1]

(b) _____ [3]



41. Gina and Hazel had the same amount of money. After Gina spent \$59 and Hazel spent \$5, Hazel had 4 times as much money left as Gina.
Find the total amount of money Gina and Hazel had altogether at first.

Ans: _____ [4]



42. Jane painted a grey square on rectangle ABCD as shown below.

The length of BC is twice of EC. The length of AD is $\frac{1}{2}$ of AB. Find the area of the unpainted part of rectangle ABCD.

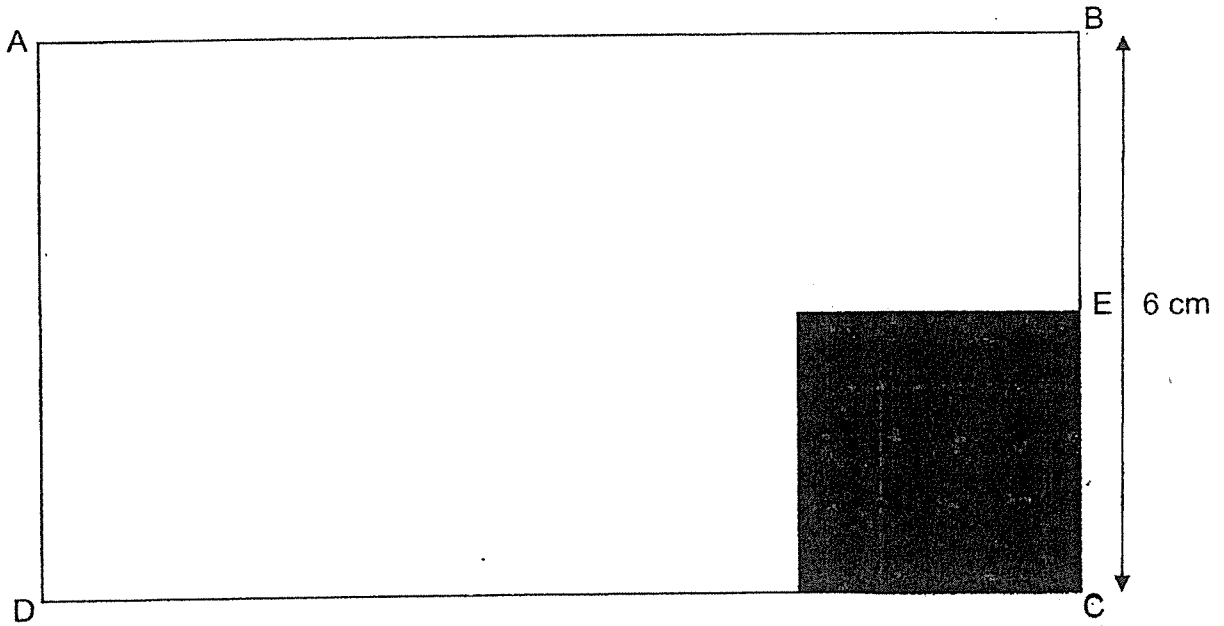

Ans: _____ [3]

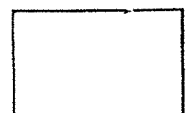

43. Katy uses sticks and buttons to form figures that follow a pattern. The first four figures are show below.

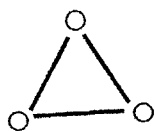

Figure 1

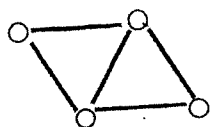

Figure 2

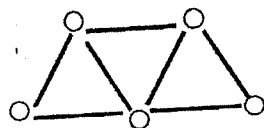

Figure 3

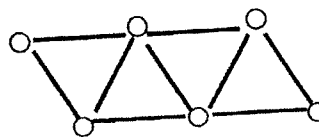

Figure 4

- (a) The table shows the number of sticks and buttons Katy used for each figure. Complete the table for Figure 5. [1]

Figure Number	1	2	3	4	5
Number of sticks	3	5	7	9	
Number of buttons	3	4	5	6	7

- (b) A figure in the pattern has a total of 129 buttons. What is the figure number of that pattern?
- (c) How many sticks are there in Figure 17?

Ans: (b) _____ [1]

(c) _____ [2]

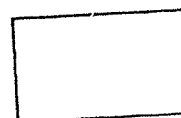

-END OF PAPER-

ANSWER KEY

LEVEL : Primary 4
SCHOOL : Henry Park Primary School
SUBJECT : MATHEMATICS
TERM : SA2

Section A

Q1	2	Q2	2	Q3	1	Q4	3	Q5	4
Q6	1	Q7	3	Q8	1	Q9	2	Q10	4

Section B

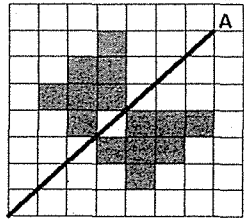
Q11	67895	Q12	10 and 5
Q13	748	Q14	$1\frac{7}{10}$
Q15	$\frac{3}{4}, \frac{2}{3}, \frac{5}{12}$	Q16	$\frac{3}{5}$
Q17	0.66	Q18	28
Q19	f	Q20	28cm
Q21	18	Q22	\$12
Q23	0.46kg	Q24	6.45
Q25	145°	Q26	110°
Q27	36cm	Q28	1615
Q29	\$154	Q30	*Draw a bar that reads \$150 *
Q31	\$5	Q32	\$40
Q33	\$1.55	Q34	59.84kg
Q35			

Section C

Q36	(a) $125 \times 15 = 1875$ $1875 + 7 = 1882$ (b) $180 \times 15 = 2700$ $2700 - 1882 = 818$	Q37	(a) $9 \times 0.8 = 7.2 \text{ kg}$ (b) $\$12,50 \times 4 = \50
Q38	(a) $3 \text{ h } 10 \text{ min} - 50 \text{ min} = 2 \text{ h } 20 \text{ min}$	Q39	(a) $\frac{1}{5} = \frac{2}{10}$

	2h20min-1h25min=55min (b) 2150+1h25min=2315		$1 - \frac{7}{10} - \frac{2}{10} = \frac{1}{10}$ (b) $300 \div 10 = 30$ $7 \times 30 = 210$ $2 \times 30 = 60$ $210 - 60 = 150$
Q40	(a) $23 \div 3 = 7R2$ Ans : 2cm (b) $10 \div 3 = 3R1$ $7 \times 3 = 21$	Q41	$59 - 5 = 54$ $54 \div 3 = 18$ $18 + 59 = 77$ $77 \times 2 = 154$
Q42	$6 \times 12 = 72$ $3 \times 3 = 9$ $72 - 9 = 63 \text{cm}^2$	Q43	(a) 11 (b) Formula for no. of buttons = Fig no. + 2 $129 - 2 = 127$ (c) Formula for no. of sticks = Fig no. $\times 2 + 1$ $17 \times 2 = 34$ $34 + 1 = 35$

2

END